

enduro

DUROSTRUTTM

Technical Data and Reference Guide

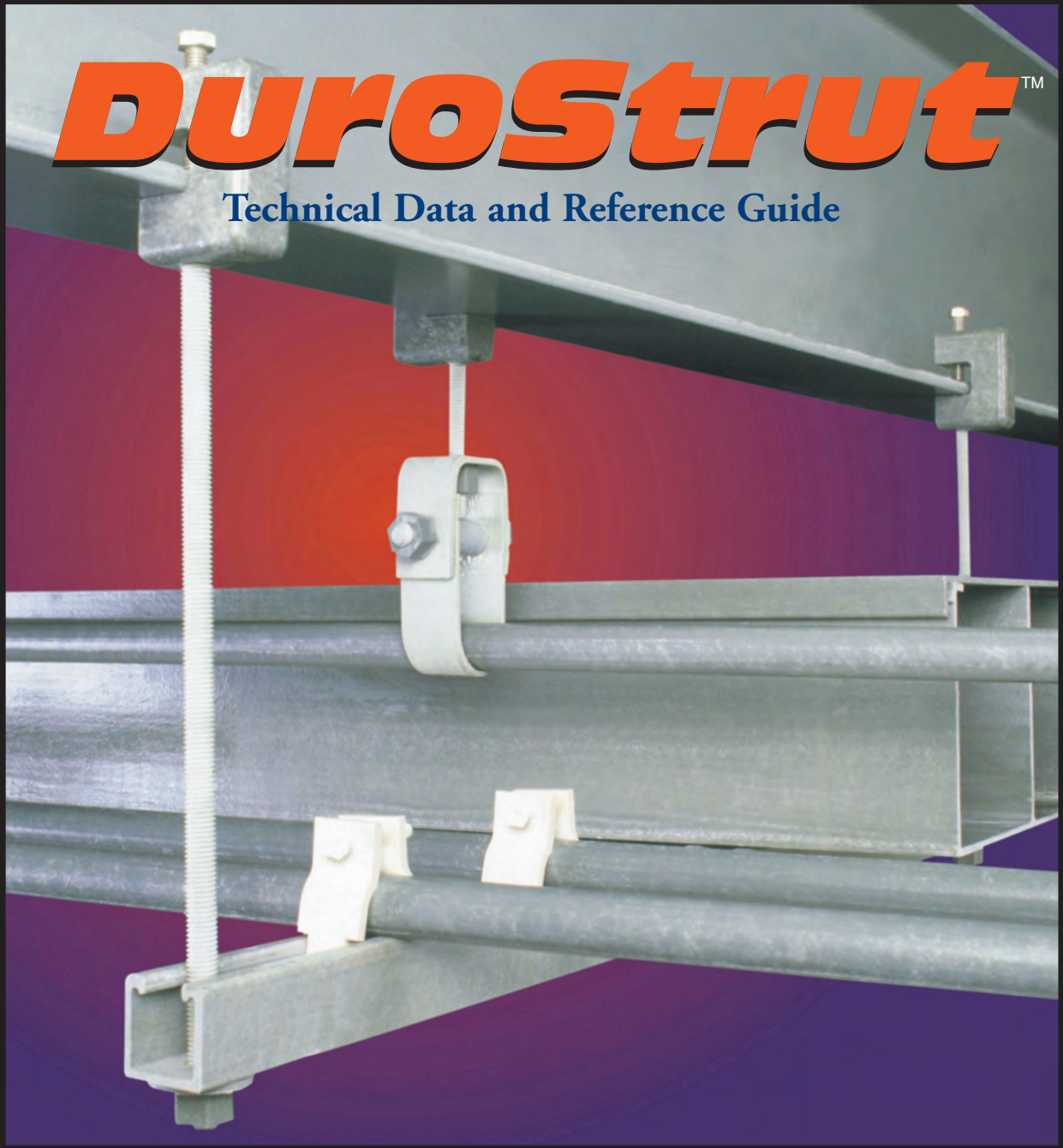

Fiberglass / Composite
***Strut, Support Systems, & Fasteners
for Cable Tray & Conduit***

DuroStrut™

Fiberglass/Composite Strut & Support Systems

Create new support systems
or add to existing cable tray.
Works with Enduro cable trays
as well as other systems.
Includes all the items necessary
to fabricate an unlimited
number of configurations...
wall mounted, floor mounted,
or hanging!

BENEFITS & QUALITIES

Corrosion Resistance –
No rusting, peeling, or flaking.

High Strength –
Strength to weight ratios that surpass
equivalent steel products.

Lightweight –
Low specific gravity...easy to handle.

Fire Retardant –
In accordance with ASTM E-84 Class I.

UV Resistant –
Contains an ultraviolet inhibiting additive
in resin and a protective veil.

Low Thermal Conductivity –
Will not transfer heat or cold
like metal products.

Cost Effective –
Extremely long life...low life cycle costs.

Easy to Install and Access –
Easy to cut and custom fabricate.

Non-interfering/Non-magnetic –
Transparent to radio waves.

enduro

a business unit of esi
16602 Central Green Blvd.
Houston, TX 77032
☎ 713.358.4000 • 📠 713.358.4100
sales@endurocomposites.com
1.800.231.7271
www.endurocomposites.com

CHANNEL FRAMING

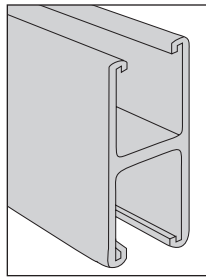

EC-158D

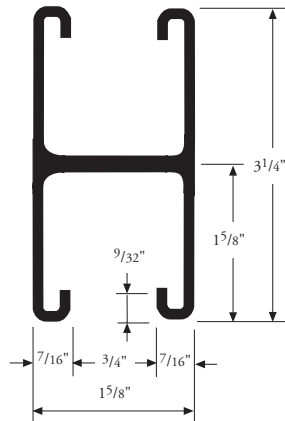

- For use in tray support systems, electrical conduit and tray rungs for tying down cable.
- Available in 10 Ft. and 20 Ft. lengths.
- Refer to Table 1 on Page 6 for Loading Information.

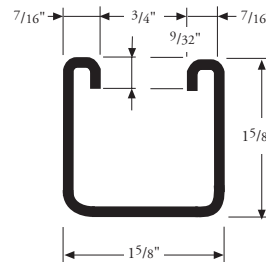

EC-158

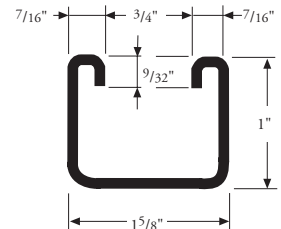

EC-10

| Catalog No. Lbs./Ft. | Polyester Resin | | |
|-------------------------|-------------------|-----------|------------|
| | EC-10 | EC-158 | EC-158D |
| 0.47 | 0.68 | 1.36 | |
| Catalog No. Lbs./Ft. | Vinyl Ester Resin | | |
| | EC-VE-10 | EC-VE-158 | EC-VE-158D |
| 0.47 | 0.68 | 1.36 | |

STRUT POST BASE

- Available for both single and double strut.

PB-1V

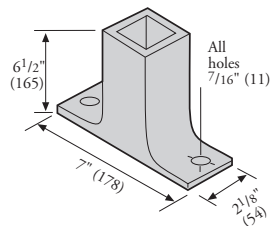

- Single - Available in Vinyl Ester

Catalog No. PB-1V

- Single - Available in Polyester or Polyurethane

Catalog No. PBS-PE (Polyester) / PBS-PU (Polyurethane)

- Double - Available in Polyester or Polyurethane

Catalog No. PBD-PE (Polyester) / PBD-PU (Polyurethane)

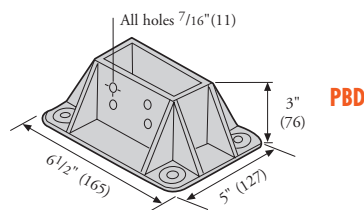

PBD

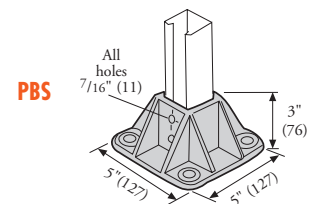

PBS

PUNCHED CHANNEL FRAMING

- Available in Polyester and Vinyl Ester resin types.
- Standard Lengths: 10 Ft. and 20 Ft.
- 9/16" holes on 2" centers.
- Replaces drilled strut.

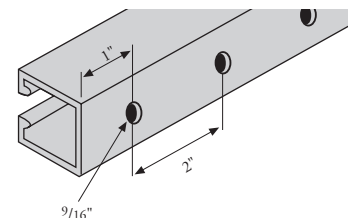

| Catalog No. Resin | EC-10H Polyester | EC-158H Polyester | EC-VE-10H Vinyl Ester | EC-VE-158H Vinyl Ester |
|----------------------|---------------------|----------------------|--------------------------|---------------------------|
|----------------------|---------------------|----------------------|--------------------------|---------------------------|

DuroStrut CONNECTOR PLATES

- Based on individual applications, changes may be required on dimension and thickness of material. Please consult factory.
- Holes are drilled to accept $\frac{3}{8}$ " and $\frac{1}{2}$ " bolts.

For Vinyl Ester Connector Plates, insert the letters "VE" as indicated in this example:

CP-100 (Polyester)

CP-VE-100 (Vinyl Ester)

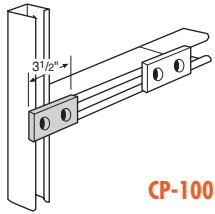

CP-100

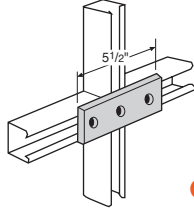

CP-101

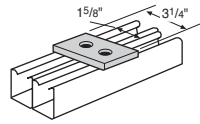

CP-102

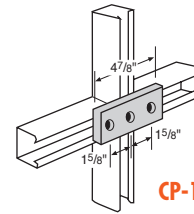

CP-103

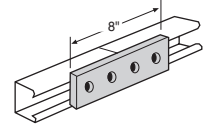

CP-104

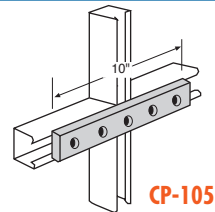

CP-105

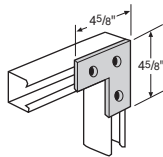

CP-109

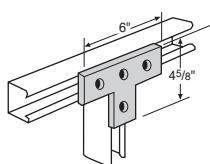

CP-110

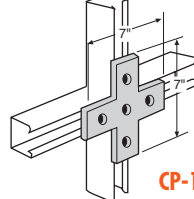

CP-111

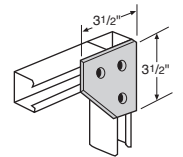

CP-112

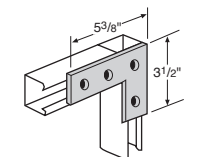

CP-113

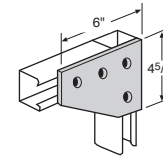

CP-114

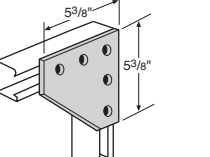

CP-115

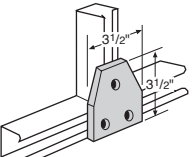

CP-116

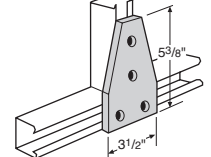

CP-117

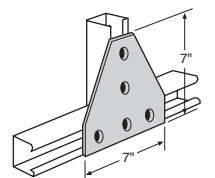

CP-118

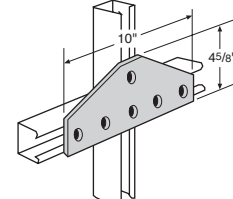

CP-119

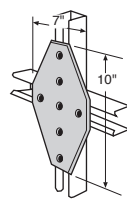

CP-120

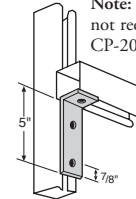

CP-205

Note: Flat washer not required for CP-205.

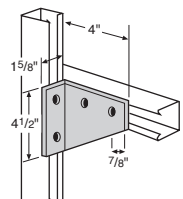

CP-209

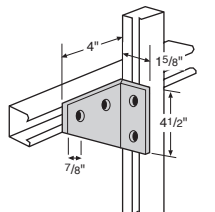

CP-210

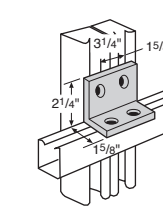

CP-211

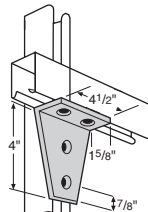

CP-226

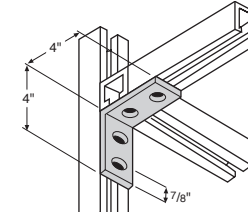

CP-405

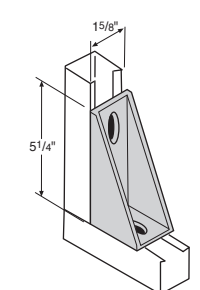

EnduroSeal FIELD CUTTING SEALANT

- Seals exposed fibers after any field cuts.
- Restores gloss and luster to weathered fiberglass.
- Seals exposed FRP threads after installation of DuroThread threaded rod and hex nuts.
- For Polyester and Vinyl Ester resin products.
- Clear color.



Meets **NSTA and UPS** requirements for sea and ground transportation.

Catalog No. Container | ES-Q Quart Can | ES-G Gallon Can

WINDOW CLAMP

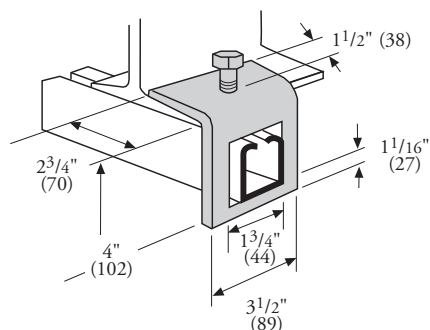

- Stainless Steel set screw included.

Part No: **WC-158**

Universal Angle CP-501

CP-501
(Polyester)

CP-PU-501
(Polyurethane)

CP-NY-501
(Nylon)

- Available in Polyester, Polyurethane (alternate to Vinyl Ester), and Nylon.

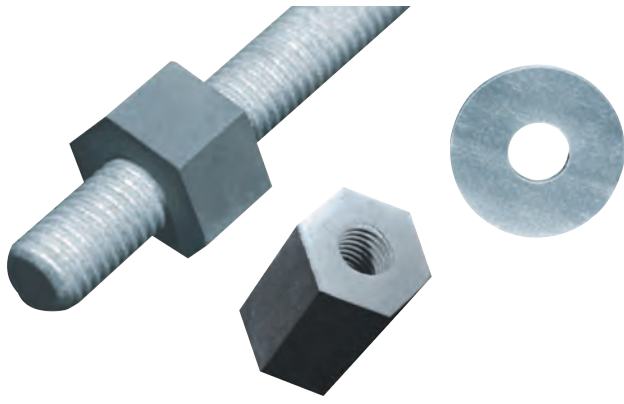

enduro

DuroThread™ Fastener & Hanging Systems

DuroThread™ is an exceptionally strong non-metallic mechanical fastener system with outstanding shear and tensile strengths. This makes the DuroThread™ fastener system an excellent choice for all structural, mechanical and electrical applications where fasteners must be corrosion resistant and/or non-conductive.

It is NOT recommended that FRP threaded rod be used in conjunction with steel or PVC coated steel beam clamps or nuts. Thread shear could occur due to insufficient thread engagement.

Refer to DuroThread™ Installation Guide on page 6, and Typical Properties for Threaded Rod on page 8.

FRP THREADED RODS

- Vinyl Ester resin.
- Available in 8 Ft. lengths.

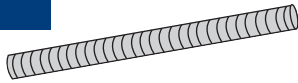

| Catalog No. | Size | Weight Lbs./Ft. |
|-------------|-------------|-----------------|
| TR-FRP-038 | 3/8"-16 UNC | 0.07 |
| TR-FRP-050 | 1/2"-13 UNC | 0.12 |
| TR-FRP-0625 | 5/8"-11 UNC | 0.18 |
| TR-FRP-075 | 3/4"-10 UNC | 0.28 |
| TR-FRP-100 | 1"-8 UNC | 0.50 |

FRP FLAT WASHERS

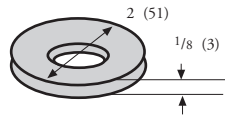

| Catalog No. | Size | Weight Lbs./Ft. |
|-------------|-------------|-----------------|
| FW-FRP-038 | 3/8"-16 UNC | 1.3 |
| FW-FRP-050 | 1/2"-13 UNC | 1.3 |
| FW-FRP-0625 | 5/8"-11 UNC | 1.3 |
| FW-FRP-075 | 3/4"-10 UNC | 1.3 |
| FW-FRP-1000 | 1"-8 UNC | 1.3 |

FRP HEX NUTS

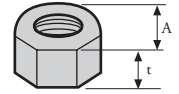

- Vinyl Ester resin.

| Catalog No. | Size | Weight Lbs./Ft. | τ = In. (mm) | A = In. (mm) |
|-------------|-------------|-----------------|--------------|--------------|
| FN-FRP-038 | 3/8"-16 UNC | 2.43 | 5/8 (16) | 7/8 (22) |
| FN-FRP-050 | 1/2"-13 UNC | 2.17 | 5/8 (16) | 7/8 (22) |
| FN-FRP-0625 | 5/8"-11 UNC | 6.05 | 7/8 (22) | 1 1/4 (32) |
| FN-FRP-075 | 3/4"-10 UNC | 5.42 | 7/8 (22) | 1 1/4 (32) |
| FN-FRP-1000 | 1"-8 UNC | 20.49 | 1 1/4 (32) | 2 (51) |

FRP ROD COUPLERS

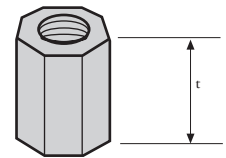

- Vinyl Ester resin.

IMPORTANT:

Minimum thread engagement must be 3/4" per side.

| Catalog No. | Size | Weight Lbs./Ft. | τ = In. (mm) |
|-------------|-------------|-----------------|--------------|
| RC-FRP-038 | 3/8"-16 UNC | 7.80 | 2 (51) |
| RC-FRP-050 | 1/2"-13 UNC | 7.00 | 2 (51) |
| RC-FRP-0625 | 5/8"-11 UNC | 13.73 | 2 (51) |
| RC-FRP-075 | 3/4"-10 UNC | 12.66 | 2 (51) |
| RC-FRP-1000 | 1"-8 UNC | 44.03 | 2 3/4 (70) |

FRP CHANNEL NUTS

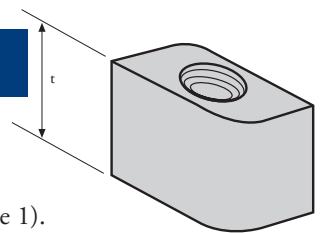

- Vinyl Ester resin.
- Channel Nuts are self locking and designed for use with EC-158 and EC-158D DuroStrut™ only (see page 1).
- Resistance to slip = 450 Lbs. per bolt.
- Pull out strength = 700 Lbs. per bolt.
- Recommended safety factor = 3.

| Catalog No. | Size | Weight Lbs./Ft. | τ = In. (mm) |
|-------------|-------------|-----------------|--------------|
| CN-038 | 3/8"-16 UNC | 5.46 | 1 1/16 (27) |
| CN-050 | 1/2"-13 UNC | 5.00 | 1 1/16 (27) |

BEAM CLAMPS

- Ultimate Load = 300 Lbs.
- Recommended safety factor = 3.
- SS set screws included with clamps.

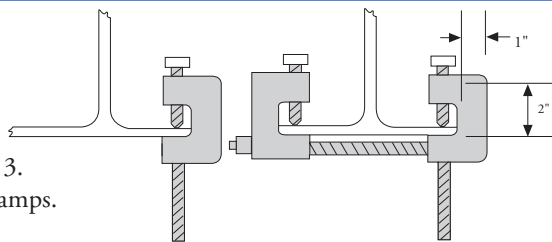

Single

Double

| Description | Catalog No. |
|----------------------------------|-------------|
| Single for 3/8" FRP Threaded Rod | BCS-3/8 |
| Single for 1/2" FRP Threaded Rod | BCS-1/2 |
| Double for 3/8" FRP Threaded Rod | BCD-3/8 |
| Double for 1/2" FRP Threaded Rod | BCD-1/2 |

"NON-METALLIC" UNIVERSAL PIPE CLAMPS

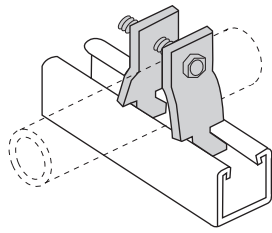

- For rigid, PVC coated steel, PVC Schedule 40 & 80 and fiberglass conduit.
- Made from a toughened grade of glass reinforced thermoplastic polyester resin.
- Standard fasteners are nylon slotted hex bolt and nut. Recommended for horizontal use as shown. For vertical placement please contact factory.

- Packaged twenty sets per bag.
- If stainless steel fasteners are preferred, indicate by adding the letter "S" after the catalog number (Example: PC-1609S).

* Includes nylon bolt.



CONDUIT SWIVEL CLAMP

- This allows an easy transition to/from conduit and FRP cable tray.

- Please substitute Enduro cable tray type when ordering (Example: TD=EHL6).
- Pipe clamps are a separate order item. See above.

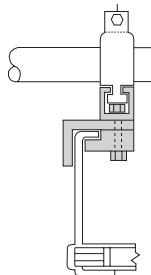

Catalog No. ECTC-(TD)-VE = Vinyl Ester
 Catalog No. ECTC-(TD) = Polyester

VERTICAL TRAY HANGER SUPPORT

Tray Depth
 Inches (mm) Catalog No.

| Polyester Resin | |
|-------------------|-------|
| 3 (76) | VH-3P |
| 4 (102) | VH-4P |
| 6 (152) | VH-6P |
| 8 (203) | VH-8P |
| Vinyl Ester Resin | |
| 6 (152) | VH-6V |

Note: Not available for EMZ6 tray.

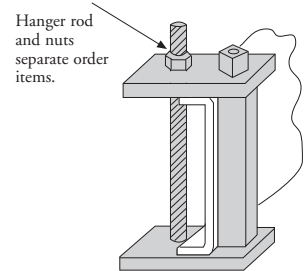

FIBERGLASS CLEVIS HANGERS

- Vinyl Ester resin.
- Allowable loads have a 3:1 safety factor at 120°F.
- Insulation may be required at higher temperatures.
- Tolerance is 3/4" maximum.

| Catalog No. | Nominal Dia. In. | Dimension Inches | | | Hanger Rod In. | Allowable Load Lbs. |
|-------------|------------------|----------------------------------|---------------------------------|----------------------------------|----------------|---------------------|
| | | A | B | C | | |
| CH-010 | 1 | 1 ⁵ / ₈ | 4 ³ / ₄ | 3 | 1/2 | 200 |
| CH-015 | 1 1/2 | 2 ¹ / ₈ | 5 ⁵ / ₈ | 3 ³ / ₈ | 1/2 | 200 |
| CH-020 | 2 | 2 ¹ / ₂ | 7 | 4 ³ / ₈ | 1/2 | 200 |
| CH-025 | 2 1/2 | 3 ⁵ / ₁₆ | 6 ⁹ / ₁₆ | 4 ¹ / ₄ | 1/2 | 200 |
| CH-030 | 3 | 3 ³ / ₄ | 7 ¹ / ₂ | 4 ¹ / ₄ | 1/2 | 300 |
| CH-040 | 4 | 5 ¹ / ₈ | 9 ³ / ₄ | 5 ⁷ / ₈ | 1/2 | 400 |
| CH-060 | 6 | 7 ³ / ₁₆ | 12 ³ / ₈ | 8 | 1/2 | 600 |
| CH-080 | 8 | 9 ³ / ₈ | 15 ⁹ / ₁₆ | 10 ¹ / ₄ | 1/2 | 600 |
| CH-100 | 10 | 11 ¹⁹ / ₃₂ | 19 ⁷ / ₈ | 12 ¹¹ / ₁₆ | 5/8 | 600 |
| CH-120 | 12 | 13 ⁵ / ₈ | 22 ¹ / ₄ | 14 | 5/8 | 600 |
| CH-140 | 14 | 15 ¹ / ₄ | 26 ³ / ₁₆ | 16 ³ / ₄ | 5/8 | 600 |

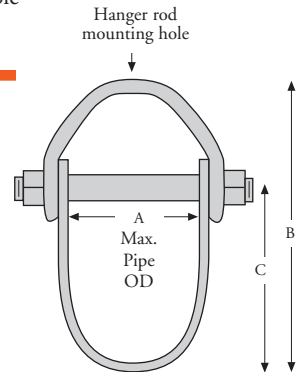

CABLE TRAY SUPPORT RACKS

Allowable load is based on a total load, uniformly distributed over the length of the rack. Safety factor = 2.0

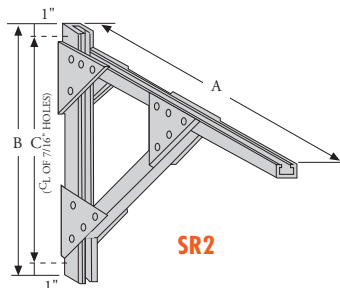
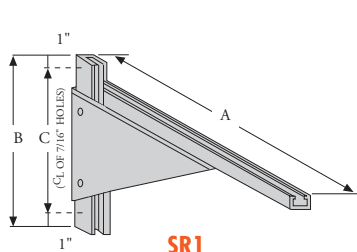

| Catalog No. Polyester Resin | Catalog No. Vinyl Ester Resin | Dimensions In. | | | Allowable Load Lbs. |
|-----------------------------|-------------------------------|----------------|----|----|---------------------|
| | | A | B | C | |
| SR1-6P | SR1-6V | 10 | 12 | 10 | 1,600 |
| SR1-9P | SR1-9V | 13 | 12 | 10 | 1,100 |
| SR1-12P | SR1-12V | 16 | 12 | 10 | 850 |
| SR1-18P | SR1-18V | 22 | 12 | 10 | 725 |
| SR1-24P | SR1-24V | 28 | 12 | 10 | 480 |
| SR2-24P | SR2-24V | 28 | 23 | 21 | 750 |
| SR2-30P | SR2-30V | 34 | 26 | 24 | 750 |
| SR2-36P | SR2-36V | 40 | 29 | 27 | 750 |

Table 1 Beam and Column Data: Polyester and Vinyl Ester Resin Base

| Beam Span or Column Height In. (mm) | Catalog No. | Maximum Allowable Uniform Beam Load | | Deflection @ Maximum Allowable Uniform Beam Load | | Uniform Load @ Maximum Deflection = 0.25 In. (6mm) | | Uniform Load @ Maximum Deflection = 0.50 In. (13mm) | | Maximum Allowable Column Load Lbs. (kg) |
|-------------------------------------|-------------|-------------------------------------|-----------------|--|----------------|--|-----------------|---|-----------------|---|
| | | Poly Lbs. (kg) | Vinyl Lbs. (kg) | Poly In. (mm) | Vinyl In. (mm) | Poly Lbs. (kg) | Vinyl Lbs. (kg) | Poly Lbs. (kg) | Vinyl Lbs. (kg) | |
| 12 (305) | EC-10 | 790 (358) | 990 (449) | 0.11 (3) | 0.12 (3) | • • | • • | • • | • • | 2550 (1156) |
| | EC-158 | 1720 (780) | 2150 (975) | 0.07 (2) | 0.07 (2) | • • | • • | • • | • • | 3650 (1655) |
| | EC-158D | 5080 (2301) | 6350 (2880) | 0.04 (1) | 0.04 (1) | • • | • • | • • | • • | 7300 (3111) |
| 18 (457) | EC-10 | 530 (240) | 670 (304) | 0.24 (6) | 0.27 (7) | • • | 620 (281) | • • | • • | 2350 (1066) |
| | EC-158 | 1150 (521) | 1440 (653) | 0.15 (4) | 0.17 (4) | • • | • • | • • | • • | 3370 (1528) |
| | EC-158D | 5080 (2301) | 4240 (1923) | 0.09 (2) | 0.10 (2) | • • | • • | • • | • • | 6740 (3058) |
| 24 (610) | EC-10 | 400 (181) | 500 (227) | 0.43 (11) | 0.48 (12) | 240 (109) | 270 (122) | • • | • • | 2070 (939) |
| | EC-158 | 860 (390) | 1080 (490) | 0.27 (7) | 0.30 (8) | 810 (367) | 910 (412) | • • | • • | 2960 (1342) |
| | EC-158D | 2540 (1152) | 3180 (1442) | 0.16 (4) | 0.17 (4) | • • | • • | • • | • • | 5920 (2685) |
| 30 (762) | EC-10 | 320 (145) | 400 (181) | 0.67 (17) | 0.75 (19) | 120 (54) | 140 (63) | 240 (109) | 270 (122) | 1710 (775) |
| | EC-158 | 690 (313) | 870 (394) | 0.42 (11) | 0.48 (12) | 410 (186) | 460 (209) | • • | • • | 2450 (1111) |
| | EC-158D | 2040 (925) | 2550 (1156) | 0.24 (6) | 0.27 (7) | 2000 (907) | 2350 (1066) | • • | • • | 4900 (2222) |
| 36 (914) | EC-10 | 270 (122) | 340 (154) | 0.98 (25) | 1.10 (28) | 70 (31) | 80 (36) | 140 (63) | 160 (72) | 1260 (571) |
| | EC-158 | 580 (263) | 730 (331) | 0.61 (15) | 0.69 (19) | 240 (109) | 270 (122) | 480 (217) | 540 (245) | 1800 (816) |
| | EC-158D | 1700 (771) | 2130 (966) | 0.35 (9) | 0.39 (10) | 1220 (553) | 1370 (621) | • • | • • | 3600 (1633) |
| 42 (1067) | EC-10 | 230 (104) | 290 (131) | 1.32 (34) | 1.49 (38) | 50 (22) | 55 (25) | 100 (45) | 115 (52) | 920 (417) |
| | EC-158 | 490 (222) | 620 (281) | 0.82 (21) | 0.92 (23) | 150 (68) | 170 (77) | 300 (136) | 340 (154) | 1320 (598) |
| | EC-158D | 1460 (662) | 1830 (830) | 0.48 (12) | 0.62 (16) | 770 (349) | 870 (394) | 1510 (650) | 1720 (780) | 2640 (1197) |
| 48 (1219) | EC-10 | 200 (91) | 250 (113) | 1.72 (44) | 1.92 (49) | 30 (13) | 35 (16) | 60 (27) | 70 (31) | 700 (317) |
| | EC-158 | 430 (195) | 540 (245) | 1.07 (27) | 1.20 (30) | 100 (45) | 115 (52) | 200 (90) | 230 (104) | 1010 (458) |
| | EC-158D | 1270 (576) | 1590 (721) | 0.62 (16) | 0.69 (17) | 520 (236) | 590 (267) | 1040 (471) | 1170 (530) | 2020 (916) |
| 60 (1524) | EC-10 | 160 (72) | 200 (91) | 2.68 (68) | 2.99 (76) | 20 (9) | 23 (10) | 40 (18) | 45 (20) | 180 (81) |
| | EC-158 | 350 (158) | 400 (200) | 1.70 (43) | 1.91 (48) | 60 (27) | 70 (32) | 120 (54) | 135 (61) | 260 (118) |
| | EC-158D | 1020 (462) | 1280 (580) | 0.97 (25) | 1.09 (28) | 270 (122) | 310 (140) | 540 (245) | 610 (276) | 520 (235) |
| 72 (1829) | EC-10 | 140 (63) | 180 (81) | * * | * * | 10 (4) | 12 (5) | 20 (9) | 23 (10) | • • |
| | EC-158 | 290 (131) | 370 (168) | 2.44 (62) | 2.78 (71) | 30 (13) | 34 (15) | 60 (27) | 70 (32) | • • |
| | EC-158D | 850 (385) | 1070 (485) | 1.40 (35) | 1.57 (40) | 160 (72) | 180 (81) | 320 (145) | 360 (163) | • • |
| 84 (2134) | EC-10 | 120 (54) | 150 (68) | * * | * * | NR | • • | 12 (5) | 15 (7) | • • |
| | EC-158 | 250 (113) | 320 (145) | * * | * * | 20 (9) | 23 (10) | 40 (18) | 45 (20) | • • |
| | EC-158D | 730 (331) | 920 (417) | 1.91 (48) | 2.15 (55) | 100 (45) | 115 (52) | 200 (90) | 230 (104) | • • |
| 96 (2438) | EC-10 | 100 (45) | 130 (59) | * * | * * | NR | • • | • • | • • | • • |
| | EC-158 | 220 (100) | 250 (113) | * * | * * | 13 (6) | 15 (7) | 26 (12) | 30 (13) | • • |
| | EC-158D | 640 (290) | 800 (363) | 2.50 (63) | 2.79 (71) | 70 (32) | 80 (36) | 140 (63) | 160 (72) | • • |

Loading Table Description

Beam Loads: Table lists the total allowable load for various simple spans based on a minimum safety factor 2:1. If load is concentrated at center of span, multiply the load from the table by 0.5 and the corresponding deflection by 0.8.

Column Loads: Table lists the total allowable axial load for various unsupported column heights based on a minimum safety factor of 3:1. Eccentric loads should be reduced according to standard practice.

Notes: All beams should be supported in a manner to prevent rotation at supports. Long, deep beams should be tied between supports to prevent twist.

* = Deflection is in excess of 3.00 In. (76mm); mid-span support is recommended.
NR = Not Recommended

Enduro DuroStrut™ Guide Specification

1.0 Scope

1.1 This specification covers the requirements for Enduro Composite System's non-metallic Channel Framing Systems & Accessories.

2.0 Standards

2.1 All channel shall have a flame spread rating of 25 or less, and the Smoke Developed Index shall have a density of 450 or less when tested in accordance with the provisions of ASTM E-84; therefore qualifying as a class 1 material in the Uniform Building Code.

2.2 All channel shall have a Nexus polyester surfacing veil over the entire surface in addition to a UV inhibitor in the resin system to protect against degradation from ultra-violet light.

3.0 Materials

3.1 All channel shall be manufactured by the pultrusion process, and contain a minimum of 50% glass by weight.

3.2 All channel shall conform, as a minimum requirement, to loads and deflections shown on the tables in the latest version of the Enduro Composite System technical catalog.

4.0 Non-Metallic Pipe Clamps

4.1 All pipe clamps shall be manufactured by the injection molding process with an impact modified, 30% glass filled thermoplastic polyester resin.

4.2 All pipe clamps interlock with the channel framing described above.

4.3 All pipe clamps shall be designed for rigid PVC coated steel, Schedule 40 or 80 PVC, and filament wound fiberglass pipe or conduit. Clamps shall be adjustable to accommodate a 3/4" minimum deviation in O.D. size.

5.0 Fasteners

5.1 All fasteners shall be injection molded glass reinforced nylon, 316 stainless steel, or pultruded vinyl ester rod with ground threads and compression molded vinyl ester nuts.

6.0 Acceptable Manufacturer

6.1 DuroStrut™ is manufactured and fabricated exclusively by Enduro Composite Systems – Houston, TX.

DuroThread™

INSTALLATION GUIDE

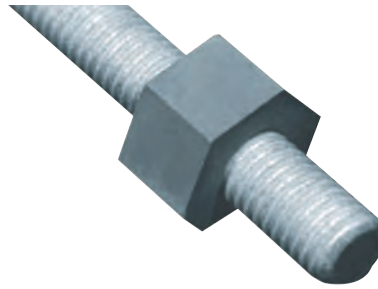

The DuroThread™ fastener system is a vinyl ester resin and fiberglass composite with unique characteristics which make it ideal for many applications where high strength, non-metallic fasteners are required.

| Size | Thread Shear (single nut) Lbs. | Maximum Installation Torque | Socket Size In. |
|---------------|--------------------------------------|-----------------------------------|-----------------------|
| 3/8" – 16 UNC | 1,250 | 4 Ft.-Lbs. | 15/16 |
| 1/2" – 13 UNC | 2,200 | 8 Ft.-Lbs. | 15/16 |
| 5/8" – 11 UNC | 3,100 | 16 Ft.-Lbs. | 15/16 |
| 3/4" – 10 UNC | 4,500 | 24 Ft.-Lbs. | 15/16 |
| 1" – 10 UNC | 6,500 | 50 Ft.-Lbs. | 2 |

Installation Instructions

For Access After Installation

If the assembly will require occasional removal of the nuts, the rod should be lightly coated with a dry lubricant, silicon spray, or a light oil prior to assembly.

For Permanent Installation

If the assembly is designed to be a permanent installation, the nuts and studs should be bonded with an epoxy adhesive. Apply a light coating of adhesive to the stud and nut threads, then quickly secure the assembly before adhesive has time to set, otherwise the mil thickness of the adhesive will make it impossible to thread. Next, apply a thick coat of adhesive to the exposed stud and nut surfaces. This provides a locking mechanism which eliminates the need for extra torque and lock washers.

For Hanging System Installation

The optimum method of installation for a hanger system is to finger tighten the assembly and then only tighten the nuts one-half turn to secure any jam nut assemblies. Follow the permanent installation procedure whenever possible. This results in minimum torque and allows maximum thread shear.

To insure maximum resistance to chemical attack once the assembly is completed, the exposed stud thread and nut surfaces should be coated with EnduroSeal™ (Part No. ES-Q or ES-G; see page 2).

Metal and FRP Installation

When utilizing metal fasteners, connectors, or nuts, consideration must be given to reduced strengths. DuroThread™ rod and nuts are designed with maximum thread engagement and extra nut thickness. Metal products have less thread engagement. When installation requires metal components, special tests may be necessary to define ultimate strengths of the fastener systems.

For Beam Clamp Installation

Maximum installation torque of 10 foot-pounds is recommended to secure set screw.

Site Conditions

Vibration and dynamic loading conditions on the DuroThread™ assembly should be eliminated or minimized. If this is not possible, additional safety factors should be used in designing the fastener system.

Tools Required

The oversize hex nut design of the DuroThread™ nut requires a larger than normal socket wrench, but either a six point or twelve point socket will work.

Important – do not exceed the torque values listed in the table on the left.

Caution

Do not over torque the DuroThread™ nut and rod. The thread shear and torque values are NOT mutually exclusive, they are additive.

Example:

1/2" – 13 has a thread shear of 2,200 Lbs. and an ultimate torque strength of 18 foot-pounds. If you use the maximum installation torque of 8 foot-pounds, the amount of thread shear remaining is reduced to 1,225 pounds.

Specifying engineers should apply this information at the design stage, applying the proper safety factors to ensure a secure installation.

Typical Hanging Support System

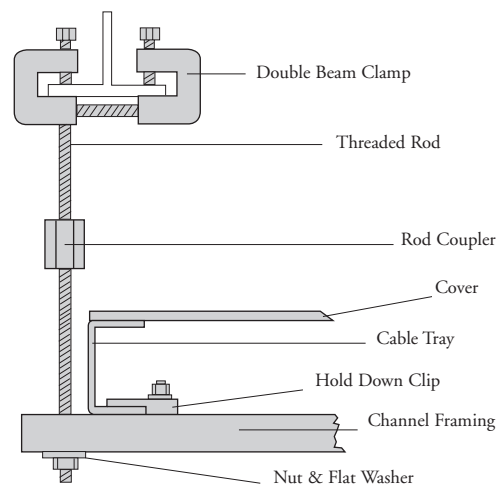

EFFECT OF TEMPERATURE FRP

Strength properties of reinforced plastics are reduced when continuously exposed to elevated temperatures. Working loads shall be reduced when based on the following:

| Temperatures in Degree F | Polyester Resin % of Strength | Vinyl Ester Resin % of Strength |
|--------------------------|-------------------------------|---------------------------------|
| 75 | 100 | 100 |
| 100 | 90 | 100 |
| 125 | 78 | 100 |
| 150 | 68 | 90 |
| 175 | 60 | 90 |
| 200 | 52 | 75 |

Note: Percentages shown are approximate. If unusual temperature conditions exist, the manufacturer should be consulted. Below freezing temperatures do not adversely affect the load rating capability of the tray. Fiberglass does not become brittle at below freezing temperatures. Careful review should be made of applications involving service temperatures over 200°F.

The test values in the following chart were obtained from tests conducted by Enduro's vinyl ester resin supplier. The values shown, although obtained from an actual coupon test, are intended for illustrative purposes only, and not for use in design calculations. The values for polyester are slightly lower.

| Test Temp. °F | -100 | -50 | 0 | 50 | 77 | 100 | 150 | 200 | 250 | 300 |
|---|---------|--------|--------|--------|--------|--------|--------|--------|--------|--------|
| Table 3 Flex. St., PSI, ASTM D790 | 101,500 | 86,400 | 79,500 | 72,300 | 68,100 | 66,300 | 58,700 | 27,400 | 13,200 | 9,200 |
| Flex. Mod., PSI x 10 ⁶ , ASTM D790 | 3.36 | 3.32 | 3.42 | 3.38 | 3.24 | 3.29 | 3.07 | 1.98 | 0.98 | 0.83 |
| Tensile St., PSI, ASTM D638 | 84,100 | 70,400 | 63,900 | 58,000 | 56,100 | 54,600 | 49,900 | 41,800 | 29,600 | 22,000 |

CORROSION RESISTANCE RESIN SYSTEMS

where strong acids (such as hydrochloric acid), strong alkalis (such as caustic soda), organic solvents and halogenated organic conditions exist. An abbreviated Guide is provided below to assist in the selection of the proper resin system for individual application.

Two standard composite resin systems are available. For most applications, isophthalic polyester fire-retardant (FR-P) is the more widely used. A vinyl ester composite fire-retardant resin system (FR-VE) is recommended

All composite material has an ultra-violet light inhibiting chemical additive and has a maximum flame spread of 25 or less, per ASTM E-84 (Class 1 flame spread). All pultruded products have complete Nexus Veil Coverage (outer surfacing fabric) to provide maximum chemical and UV protection.

Table 4 Corrosion Resistance Guide

| Chemicals | 75°F | 160°F | Chemicals | 75°F | 160°F |
|-------------------------------|-----------|--------------------|---------------------------|-------|----------------|
| Acetic Acid 5% | FR-P | FR-P | Methyl Alcohol 10% | FR-P | FR-VE-150° (*) |
| Acetic Acid 25% | FR-P | FR-VE-210° (*) | Naphtha | FR-P | FR-P |
| Aluminum Potassium Sulfate 5% | FR-P | FR-P | Nitric Acid 5% | FR-P | FR-P |
| Ammonium Hydroxide 10% | FR-P | FR-VE-150° | Nitric Acid 20% | FR-VE | FR-VE-120° (*) |
| Ammonium Nitrate | FR-P | FR-P | Phosphoric Acid 10% | FR-P | FR-P |
| Benzenesulfonic Acid 5% | FR-P | FR-P | Phosphoric Acid 30% | FR-P | FR-P |
| Calcium Chloride | FR-P | FR-P | Phosphoric Acid 85% | FR-P | FR-P |
| Carbon Tetrachloride | FR-VE | FR-VE-100° (*) | Sodium Bicarbonate 10% | FR-P | FR-P |
| Chlorine Dioxide 15% | FR-P | FR-VE 150° (*) | Sodium Bisulfate | FR-P | FR-P |
| Chromic Acid 5% | FR-P | FR-VE 150° (*Call) | Sodium Carbonate | FR-P | FR-VE |
| Copper Sulfate | FR-P | FR-P | Sodium Chloride | FR-P | FR-P |
| Diesel Fuel No. 1 | FR-P | FR-P | Sodium Hydroxide 1-50% | FR-VE | FR-VE-120° (*) |
| Diesel Fuel No. 2 | FR-P | FR-P | Sodium Hypochlorite 5% | FR-P | FR-VE-120° (*) |
| Ethylene Glycol | FR-P | FR-P | Sodium Nitrate | FR-P | FR-P |
| Fatty Acids 100% | FR-P | FR-P | Sodium Silicate | FR-P | FR-VE-210° (*) |
| Ferrous Sulfate | FR-P | FR-P | Sodium Sulfate | FR-P | FR-P |
| Fluosilicic Acid 0-20% | FR-VE | FR-VE (Call) | Sulfuric Acid 0-30% | FR-P | FR-P |
| Hydrochloric Acid 1% | FR-P | FR-P | Sulfuric Acid 30-50% | FR-VE | FR-VE |
| Hydrochloric Acid 15% | FR-P | FR-VE-180° (*) | Sulfuric Acid 50-70% | FR-VE | FR-VE-180° (*) |
| Hydrochloric Acid 37% | FR-P | FR-VE-150° (*) | Trisodium Phosphate 25% | FR-P | FR-VE-210° (*) |
| Hydrogen Sulfide | FR-P-140° | FR-VE-210° | Trisodium Phosphate - All | FR-VE | FR-VE-210° (*) |
| Kerosene | FR-P | FR-P | Water, Distilled | FR-P | FR-P |
| Magnesium Chloride | FR-P | FR-P | | | |

FR = Fire-Retardant P = Polyester Resin VE = Vinyl Ester Resin (*) = Not recommended to exceed this temperature. Call = Call for recommendations

Information contained in this chart is based on data from raw material suppliers and collected from several years of actual industrial applications.

Temperatures are not the minimum nor the maximum (except where specifically stated) but represent standard test conditions. The products may be suitable at higher temperatures, but individual test data should be required to establish such suitability.

The recommendations or suggestions contained in this chart are made without guarantee or representation as to results. We suggest that you evaluate these recommendations and suggestions in your own laboratory or by actual field trial prior to use.

TYPICAL PROPERTIES FRP STRUCTURAL SHAPES

Table 5

| Mechanical (coupon) | FR-P | FR-VE | Mechanical (coupon) | FR-P | FR-VE |
|--|--------|--------|--|----------------------|----------------------|
| Longitudinal Direction | | | Transverse Direction | | |
| Ultimate Tensile Strength, PSI (ASTM D638) | 30,000 | 35,000 | Ultimate Tensile Strength, PSI | 7,000 | 10,000 |
| Ultimate Compressive Strength, PSI (ASTM D695) | 30,000 | 35,000 | Ultimate Compressive Strength, PSI | 15,000 | 20,000 |
| Ultimate Flexural Strength, PSI (ASTM D790) | 30,000 | 35,000 | Ultimate Flexural Strength, PSI | 10,000 | 14,000 |
| Tensile Modulus, PSI x 10 ⁶ | 2.5 | 3.0 | Tensile Modulus, PSI x 10 ⁶ | 0.8 | 1.0 |
| Compressive Modulus, PSI x 10 ⁶ | 2.5 | 2.5 | Compressive Modulus, PSI x 10 ⁶ | 1.0 | 1.2 |
| Flexural Modulus, PSI x 10 ⁶ | 1.6 | 2.0 | Flexural Modulus, PSI x 10 ⁶ | 0.8 | 1.0 |
| Ultimate Shear Strength, PSI | 5,500 | 7,000 | Ultimate Shear Strength, PSI | 5,500 | 6,000 |
| Ultimate Bearing Stress, PSI | 30,000 | 35,000 | Ultimate Bearing Stress, PSI | 30,000 | 35,000 |
| Izod Impact Strength, Ft.-Lbs. per inch of notch (ASTM D256) | | | Izod Impact Strength, Ft.-Lbs. per inch of notch (ASTM D256) | 4 | 5 |
| (sample thickness 1/8" except 1/4" for rod) | 25 | 30 | Barcol Hardness (ASTM D2583-75) | 50 | 50 |
| Electrical | | | Full Section in Bending | | |
| Electric Strength, short term in oil, 1/8", vpm (ASTM D149)* | 200 | 200 | Modulus of Elasticity, PSI x 10 ⁶ | 2.5 | 3.0 |
| Electric Strength, short term in oil, KV per inch | 35 | 35 | Tensile Strength, PSI | 20,000 | 25,000 |
| Dielectric Constant, 60 Hz. (ASTM D150)* | 5.6 | 5.2 | Compressive Strength, PSI | 20,000 | 25,000 |
| Dissipation Factor, 60 Hz. (ASTM D150)* | 0.03 | 0.03 | Thermal | | |
| Arc Resistance, seconds (ASTM D495)** | 120 | 120 | Thermal Coefficient of Expansion, Inches/Inch/°F (ASTM D696)** | 5 x 10 ⁻⁶ | 5 x 10 ⁻⁶ |
| Fire Retardant Properties | | | Thermal Conductivity, BTU per Sq. Ft./Hr./°F/In. (ASTM C-1776-76) | 4 | 4 |
| Flame Resistance, ign/burn, seconds (FTMS 406-2023) | 75/75 | 75/75 | Specific Heat, BTU/Lb./°F | 0.28 | 0.28 |
| Intermittent Flame Test, rating (HLT-15) | 100 | 100 | Other | | |
| Flammability Test, average time of burning 5 seconds, average extent of burning 15mm (ASTM D635) | | | Density, Lbs./In. ³ (ASTM D792) | 0.065 | 0.065 |
| Surface Burning Characteristics, maximum (ASTM E84) | 15 | 15 | Specific Gravity (ASTM D792) | 1.80 | 1.80 |
| | | | Water Absorption, Max. % by weight (24 hour immersion) (ASTM D570) | .50 | .50 |

* Specimen tested perpendicular to laminate face. Note: 1 PSI = 6.894 K Pa, 1 Ft. - Lb./In. = 5.443 kg - m/m

** Indicates reported value measured in longitudinal direction.

Note: Depending on the specific glass content and resin, the strength and stiffness properties may be significantly higher.

TYPICAL PROPERTIES FRP THREADED ROD

Table 6

For additional information Refer to DuroStrut® Installation Guide on page 6.

| Properties | 3/8 -16 UNC | 1/2 -13 UNC | 5/8 -11 UNC | 3/4 -10 UNC | 1-8 UNC |
|--|----------------------------|----------------------|----------------------|----------------------|----------------------|
| Thread shear strength using fiberglass nut in tensile - Lbs. | 1,250 | 2,200 | 3,100 | 4,500 | 6,500 |
| Transverse shear on threaded rod - double shear (load Lb.) (ASTM-B565) | 3,000 | 5,000 | 7,500 | 12,000 | 22,000 |
| Transverse shear on threaded rod - single shear (load Lb.) | 1,600 | 2,600 | 3,800 | 6,200 | 15,000 |
| Compressive strength longitudinal, PSI (ASTM-D695) | 54,000 | 54,000 | 54,000 | 54,000 | 65,000 |
| Flexural strength, PSI (ASTM-D790) | 55,000 | 55,000 | 55,000 | 55,000 | 60,000 |
| Flexural modulus, PSI x 10 ⁶ (ASTM-D790) | 2.0 | 2.0 | 2.0 | 2.50 | 2.75 |
| Torque strength using fiberglass nut lubricated with SAE 10W30 motor oil, Ft.-Lbs. | 8 | 18 | 35 | 50 | 110 |
| Dielectric strength, KV/In. (ASTM-D149) | 35 | 35 | 35 | 35 | 35 |
| Water absorption 24 hour immersion - threaded, % (ASTM-D570) | 1 | 1 | 1 | 1 | 1 |
| Coefficient of thermal expansion - longitudinal In./In./°F | 5 x 10 ⁻⁶ | 5 x 10 ⁻⁶ | 5 x 10 ⁻⁶ | 5 x 10 ⁻⁶ | 5 x 10 ⁻⁶ |
| Max recommended operation temp - based on 50% retention of ultimate thread shear strength °F | 200 | 200 | 200 | 200 | 200 |
| Stud weight, Lb./Ft. | 0.07 | 0.12 | 0.18 | 0.28 | 0.50 |
| Flammability | Self-extinguishing on all. | | | | |

Note: 1 Ft.-Lb. = .138 kg-M; 1 Lb = .4536 kg, 1 PSI = 6.984 K Pa

The following applies to Tables 5 and 6

1. Refer to Table 5 (FR-VE Resin) for fire retardant properties of threaded rod.
2. Test results are for studs with single nuts only. Proper safety factors should be applied to testing.
3. All values are based on laboratory test results.

DuroStrut™

Also from enduro

StandFast™

Fiberglass/Composite Instrument & Pushbutton Stands

A universal instrument support system that offers many of the same features and benefits as our cable tray, strut and wireway systems. Constructed from 2" Schedule 80 gray vinyl ester pipe with an 8" gray square vinyl ester base. Available in a variety of combinations to fit any mounting requirements. Delivered fully assembled, or available in component parts for field assembly.



INSTRUMENT SUPPORTS

Floor Mount Single

Catalog No.:
DISR170B1x(Dim. A)
Example: DISR170B148

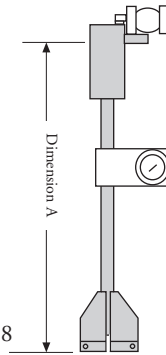

Column or Wall Mount

Catalog No.:
DISR175B48 x (Dim. A) x (Dim. B)
Example: DISR175B48x11x12

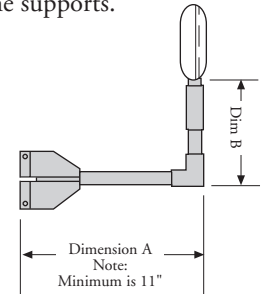

Floor Mount Double

Catalog No.:
DISR171B x (Dim. A) x (Dim. B) x (Dim. C)
Example: DISR171B48x36x18

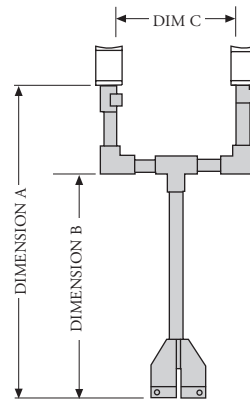

Floor Mount Multiple Instrument

Catalog No.:
DISR172B x (Dim. A) x (Dim. B) x (Dim. C)
Example: DISR172B36x12x15

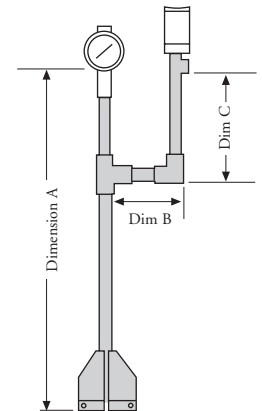

FR-VE PUSHBUTTON STATION

- Made of pultruded fiberglass reinforced vinyl ester 2" square tube with an 8" vinyl ester base.
- Please specify dimensions in inches.

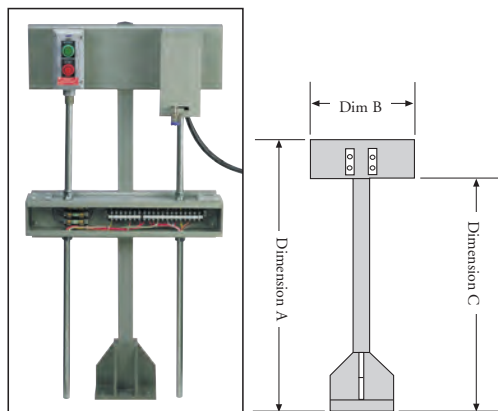

Catalog No.:
DPSx(Dim. A)x(Dim. B)x(Dim. C)
Example: DPS48x16x40

U-BOLTS

- Made from glass reinforced polyurethane resin, U-Bolts are the ideal choice for mounting enclosures, instrumentation, conduit, and piping on your StandFast™ support systems.
- Excellent as an alternative when replacing corroded steel U-Bolts.
- Recommended for operating temperatures up to 150°F.
- Four nuts included with each U-Bolt.

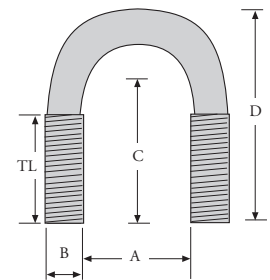

| Part Number | Pipe Nom. Dia. In. | A | B | C | D | TL | Maximum Rec. Loading Lbs. | Maximum Rec. Torque In.-Lbs. |
|-------------|--------------------|------|-------|------|------|------|---------------------------|------------------------------|
| EU050 | 1/2 | 0.93 | 0.375 | 1.56 | 2.41 | 1.25 | 75 | 20 |
| EU075 | 3/4 | 1.12 | 0.375 | 1.66 | 2.60 | 1.25 | 75 | 20 |
| EU100 | 1 | 1.37 | 0.375 | 1.78 | 2.85 | 1.25 | 75 | 20 |
| EU125 | 1 1/4 | 1.68 | 0.375 | 1.94 | 3.16 | 1.25 | 75 | 20 |
| EU150 | 1 1/2 | 2.00 | 0.375 | 2.10 | 3.47 | 1.25 | 75 | 20 |
| EU200* | 2 | 2.43 | 0.500 | 2.46 | 4.18 | 1.50 | 150 | 40 |
| EU250 | 2 1/2 | 2.93 | 0.500 | 2.71 | 4.68 | 1.50 | 150 | 40 |
| EU300 | 3 | 3.56 | 0.500 | 3.03 | 5.31 | 1.50 | 150 | 40 |
| EU350 | 3 1/2 | 4.06 | 0.500 | 3.28 | 5.81 | 1.50 | 150 | 40 |
| EU400 | 4 | 4.56 | 0.500 | 3.53 | 6.31 | 1.50 | 150 | 40 |



Tuff Span® Fiberglass Structural Shapes

Enduro offers standard and custom shapes for challenging, structural and environmental conditions. Delivering long, maintenance-free service life, the structural sections are cost effective solutions for industrial buildings in corrosive environments.

The sections are manufactured by advanced pultrusion process that provides optimum strength and stiffness, consistent properties, close

tolerances, and good surface finish. Enduro's pultrusion process produces consistent, reliable quality and glass fiber reinforcements up to 60% of the material weight.

The material's premium grade, isophthalic polyester or vinyl resin system provides outstanding corrosion protection and is fire retardant with a flame spread rating of 25 or less. The resulting combination of corrosion resistance, non-conductivity, and long span capability delivers significant end user benefits and life cost savings.

Tuff Span Standard Shapes include fiberglass reinforced plastic channel, angle, tube, wide flange, and flat plate. Enduro Composites furnishes these materials as individual structural components and in assembled products.

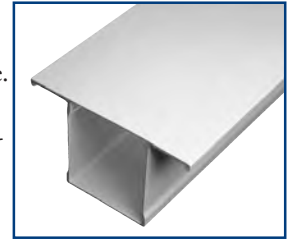





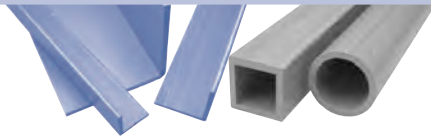

Tuff Span Flanged Box Beams are developed specifically for long span conditions required in building structures and support of tank cover decking. The 8F6 and 18F17 custom design optimizes structural properties and cost through innovative use of shape, glass fiber reinforcing, and manufacturing process. The box shape increases lateral stability and eliminates the need for bridging or lateral bracing. Within the material, continuous glass fiber reinforcements are aligned in multiple directions and are placed in greater quantity at flanges as well as upper and lower web areas. This design produces higher structural properties per weight as compared to unidirectional reinforced FRP Wide Flange and I-Beam sections.

For technical data and catalog on Tuff Span Fiberglass Structural Shapes, please contact Enduro.

TUFF SPAN® STRUCTURAL SHAPES and FLAT SHEETS



- Stocking lengths are 10 Ft. or 20 Ft.
- Flat sheet is available in 3' x 10' pieces.
- Contact factory for required shapes not listed.
- Available in Polyester and Vinyl Ester.

| Size in Inches | Lbs./Ft. | Size in Inches | Lbs./Ft. | Size in Inches | Lbs./Ft. | Size in Inches | Lbs./Ft. | Size in Inches | Lbs./Ft. |
|------------------|---|-------------------------|---|----------------------|---|---------------------|---|--------------------------------------|---|
| Channel |  | Unusual Channel | | Angle |  | Square Tube |  | Flat Strip |  |
| 2 x 1 x 3/16 | 0.37 | 4 3/4 x 3 1/4 x 1/4 | 2.06 | 1 x 1 x 1/4 | 0.17 | 1 5/8 x 1 5/8 x 1/8 | 0.56 | 4 5/8 x 1/4 | 0.75 |
| 3 x 1 x 3/16 | 0.68 | 6 7/8 x 5 3/8 x 1/4 | 3.08 | 2 x 2 x 1/4 | 0.69 | 1 3/4 x 1 3/4 x 1/4 | 1.14 | | |
| 4 x 1 3/8 x 5/32 | 0.75 | | | 3 x 3 x 1/4 | 1.04 | 2 x 2 x 1/4 | 1.40 | | |
| 4 x 1 1/8 x 1/4 | 1.13 | | | 3 x 3 x 3/8 | 1.53 | 2 x 2 1/2 x 1/4* | 1.55 | | |
| 6 x 1 5/8 x 5/32 | 1.09 | Round Tube |  | 4 x 4 x 3/8 | 2.09 | 2 1/2 x 2 1/2 x 1/4 | 1.70 | Flat Sheet Construction Grade |  |
| 6 x 1 5/8 x 1/4 | 1.70 | 2 3/8 x 1/4 | 1.45 | 4 5/8 x 1 5/8 x 3/16 | 0.94 | 3 x 3 x 1/4 | 2.20 | 1/8 Thickness | 1.41 |
| 6 x 1 5/8 x 5/16 | 2.10 | | | 5 x 5 x 3/8 | 2.81 | 3 x 4 x 1/4 | 2.51 | 3/16 Thickness | 1.71 |
| 6 x 2 x 3/16 | 1.53 | Wide Flange Beam | | 6 x 6 x 3/8 | 3.35 | 4 x 4 x 1/4 | 3.25 | 1/4 Thickness | 2.34 |
| 8 x 1 3/4 x 5/16 | 2.50 | 6 x 6 x 3/8 | 5.30 | | | | | 3/8 Thickness | 3.35 |
| 10 x 2 3/4 x 3/8 | 4.27 | | | | | | | 1/2 Thickness | 4.03 |

* Nonstock item, minimum run required.

Tuff Span® FRP Buildings

Enduro provides design assistance and supply of pre-engineered buildings that consist entirely of corrosion resistant FRP wall, roof, and structural components.



Other Typical **DuroStrut™** Installation Applications

DuroStrut™ combined with Enduro cable tray accessories are functional in many non-cable tray applications. DuroStrut™ includes all the items necessary to field fabricate to your specifications whether wall, floor, or ceiling mounted. Enduro can also assist in engineering to your requirements.

If you need a special shape or assembly, call Enduro for information on custom pultrusions and fabrications.

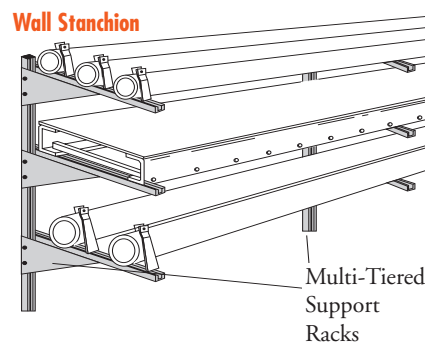
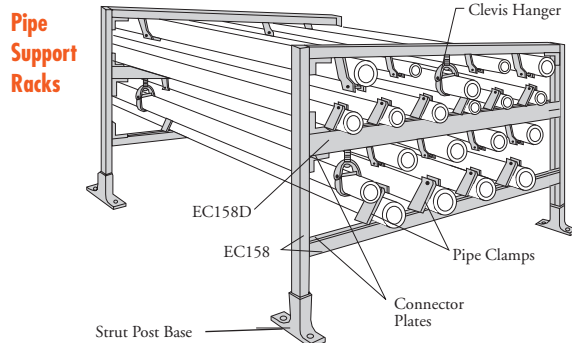

Enduro offers one of the most diversified product lines in the composites industry:

- Cable Tray Systems
- Tank Covers and Baffles
- Structural Shapes and Strut
- Tuff Span Building Panels
- Pre-Engineered Buildings
- Dual Laminate Pipe and Tanks
- DuroLite Daylighting Panels
- Custom, Engineered Materials



Information on Enduro's engineered, FRP materials is available from our staff of technical specialists and website: www.endurocomposites.com

enduro

a business unit of esi

16602 Central Green Blvd. • Houston, TX 77032

☎ 713.358.4000 • 📠 713.358.4100

sales@endurocomposites.com

1.800.231.7271 • www.endurocomposites.com

Represented by:

