

enduro

Tuff Span
FRP Structural Shapes



Corrosion Resistance For Demanding Environments

Beams • Channels • Angles • Tube • Rod • Flat Sheet

www.endurocomposites.com

Tuff Span FRP Structural Shapes

Corrosion Resistant • Long Span • Non-Conductive



Structural shapes for demanding structural and environmental conditions.

Tuff Span Flanged Tube Beams are developed specifically for applications that require long span and high load capability plus corrosion resistance. This includes building structures, baffle wall columns, and support of tank cover decking. These sections utilize a custom design that optimizes structural properties and cost through innovative use of shape, glass fiber reinforcing, and manufacturing process.

Tubular shapes are utilized to enhance lateral stability and to eliminate cross bracing. The sections include extended flanges for easy installation and connections. The materials are manufactured by pultrusion process that produces consistent, reliable quality and maximizes glass fiber reinforcements. To optimize load transfer and capacity, its reinforcements are aligned in multiple directions and strategically placed within the material. This design produces higher structural properties per weight as compared to unidirectional reinforced FRP Wide Flange and I-Beam sections.



Tuff Span 8F6 beams and roofing panels at galvanizing plant. Tuff Span building products provide outstanding corrosion protection and substantial, life-cycle cost savings.

The material's isophthalic polyester or vinyl resin system provides outstanding corrosion protection and fire retardant sections with flame spread rating of 25 or less. The combination of corrosion resistance, and long span capability delivers significant end user benefits and life cost savings.

Tuff Span Standard Shapes include fiberglass reinforced plastic channel, angle, tube, wide flange, and flat sheet sections. Enduro furnishes these materials as individual structural components and in assembled products. Uses for Tuff Span FRP structural shapes include:

- Long span roof and wall beams
- Baffle Wall columns
- Long span tank cover beams
- Primary building structures
- Cooling towers
- Cable tray
- Strut
- Threaded rod
- Instrument stands
- Ladder and handrail
- Grating support
- OEM applications



Tuff Span 8F6 and 18F17 beams at EMI Test Facility under construction. Tuff Span FRP building products are non-conductive and RF transparent.

Table of Contents

Tuff Span FRP Structurals	Pg 1
8F6 Purlin/Girt: Details/Specifications	Pg 2
Span Table Notes	Pg 3
Shape Availability/Properties	Pg 3
Load/Span Tables	Pg 4–8

enduro

16602 Central Green Blvd
Houston, TX 77032
713.358.4000 _ 800.231.7271
www.endurocomposites.com

Details: Tuff Span 8F6 FRP Purlin/Girt System

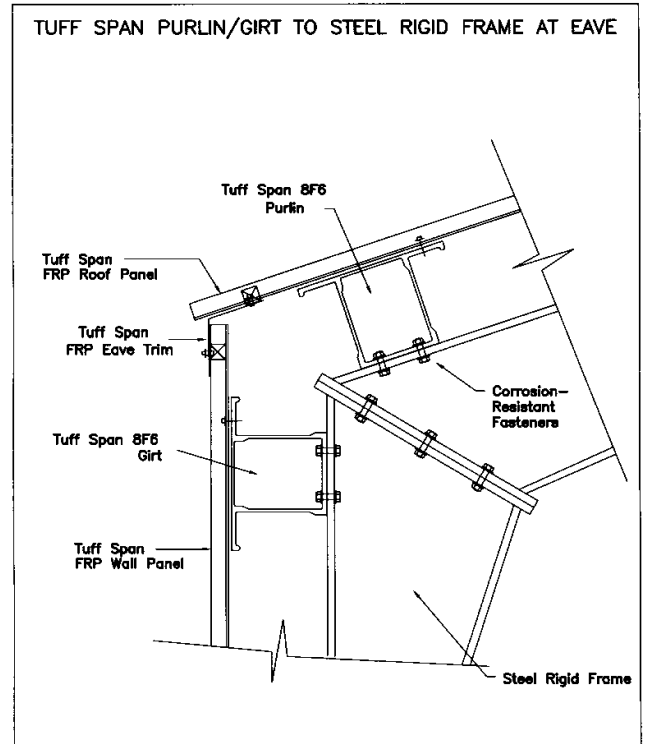
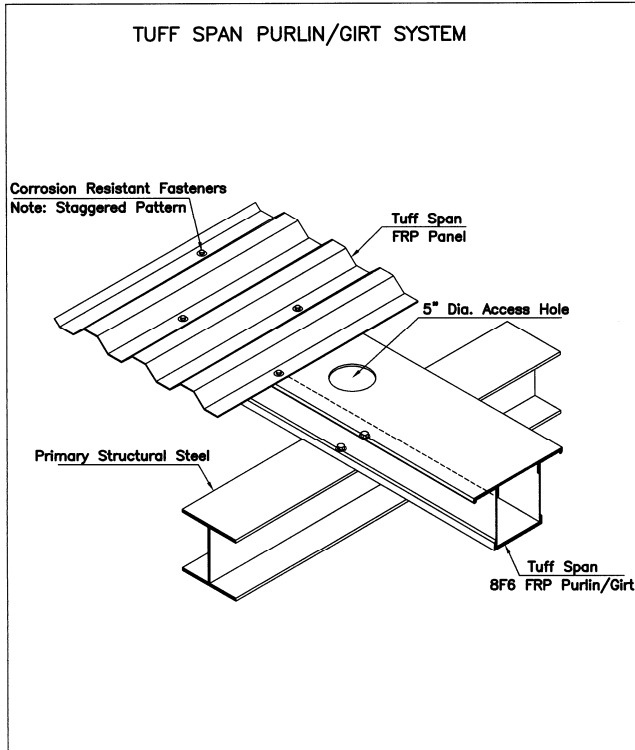

Specifications: Fiberglass Reinforced Plastic Structurals

Part 1 - General

1.01 Description of Work

The scope of this specification is intended to cover fiberglass reinforced plastic beams as shown on the drawings.

1.02 Performance Testing

- A. Materials shall comply with Federal and Local laws or ordinances, applicable codes, standards, and regulatory agency requirements including:
 1. ASTM D638, Standard Test Method for Tensile Properties of Plastics
 2. ASTM D790, Standard Test Method for Flexural Properties of Plastics
 3. ASTM D695, Standard Test Method for Compressive Strength of Plastics
 4. ASTM E84, Standard Test Method for Surface Burning Characteristics of Plastics

- A. Structural framing shall meet performance and design criteria listed herein and indicated on the drawings.
- B. Beams shall demonstrate compliance with design criteria by full-scale, 3 Point Load Bend Test.

1.03 Design Criteria

- A. Uniform Design Loads

Wind	_____psf	Snow	_____psf
Live	_____psf	Dead	_____psf
- B. Deflection Limits and Factors of Safety

Roof Purlins:	L/D = 120; FOS = 2.5
Wall Girts:	L/D = 120; FOS = 1.88
Primary Beams:	L/D = 180; FOS = 2.5

Part 2 – Products

2.01 Materials

Structural shapes shall be Tuff Span as manufactured by Enduro, Houston, Texas or approved equal.

- A. Purlin and Girts shall be Tuff Span 8F6 Flanged Tube Beam.
- B. Primary structurals shall be Tuff Span 12F12 or 18F17 Flanged Tube Beam.
- C. Resin type shall be:
 - _____ Isophthalic Polyester, gray color
 - _____ Vinyl Ester, beige color
- D. Glass fiber reinforcements shall be continuous and in multi-directional alignment with minimum glass content of 60% of the beam weight.
- E. Materials shall be fire retardant with Class I Flame Spread Rating, 25 or less per ASTM E-84.

Part 3 - Execution

3.01 Installation 8F6 Purlin / Girt

- A. Verify alignment of primary support beams.
- B. Position 8F6 beam on primary beams with flanges upward.
- C. Fasten 8F6 beam with two, 5/8" x 2" bolt and nut assemblies at each support. Access for fastening 8F6 beams is through (optional) factory-cut access holes.

FRP Structural Shapes: Span Tables

Design parameters used for the tables on the following pages are based on material testing and theoretical analysis. Allowable uniform loads, shown in lbs/ft, are limited by bending moment with applied factor of safety (FOS) and deflection (L/D) expressed as the ratio between span length and the allowable limit. This information should be used as a guide only with usage verified by a registered Professional Engineer.

Nomenclature

W = Weight per lineal foot, lb/ft

A = Cross-sectional area, in²

E = Apparent flexural modulus, psi

G = Apparent modulus of rigidity, psi

M = Bending moment capacity, lb.-in.

I_{xx} = Moment of Inertia, centroidal x-x axis, in⁴

I_{yy} = Moment of Inertia, centroidal y-y axis, in⁴

Bf/Bt = Flange width/Flange thickness ratio

K = Effective column length factor

F_b = Flexural Stress (psi)

R = Radius of Gyration (in)

A_w = Area of web (in²)

S_{xx} = Section Modulus, X-Axes (in³)

FRP Shapes	Load Table Pg. #	Stock Item (2)	Non-Stock Item (3)	FRP Shapes	Load Table Pg. #	Stock Item (2)	Non-Stock Item (3)
Flanged Beams				Angle			
8F6 Purlin/Girt	4		*	6 x 6 x 3/8 Angle	8	*	
12F12 Flanged Tube	4		*	4 x 4 x 3/8 Angle	8	*	
18F17 Flanged Tube	4		*	3 x 3 x 3/8 Angle	8	*	
6 x 6 x 3/8 Wide Flange	5	*		3 x 3 x 1/4 Angle	Note 1	*	
12S12 Flanged Tube	5		*	2 x 2 x 1/4 Angle	Note 1	*	
Rectangular Tube				Solid Rod			
14B10 Tube	5		*	1 x 1/8 Square	Note 1	*	
3 x 4 x 1/4	Note 1		*	1 x 1/8 Round	Note 1	*	
Square Tube				Round Tube			
4 x 4 x 1/4	6		*	2 3/8 x 1/4	Note 1		*
3 x 3 x 1/4	6		*	Flat Sheet			
2 x 2 x 1/4	6	*		3' x 10' x 1/8" Thick	Note 1	*	
1 5/8 x 1 5/8 x 1/8	6		*	3' x 10' x 3/16" Thick	Note 1		*
Channel				3' x 10' x 1/4" Thick	Note 1	*	
C10 x 2 3/4 x 3/8	7	*		3' x 10' x 3/8" Thick	Note 1	*	
C8 x 1 3/4 x 5/16	7	*		3' x 10' x 1/2" Thick	Note 1	*	
C6 7/8 x 5 3/8 x 1/4	Note 1	*		Flat Strip, 4 5/8 x 1/4	Note 1	*	
C6 x 1 5/8 x 5/16	7		*				
C6 x 1 5/8 x 1/4	7	*		Notes			
C6 x 2 x 3/16	Note 1	*		1) Contact Enduro for technical data.			
C6 x 1 5/8 x 3/16	Note 1	*		2) Stock Lengths: 20 ft. and 10 ft.			
C4 3/4 x 3 1/4 x 1/4	Note 1	*		3) Non-Stock Item: Contact Enduro for minimum order requirement.			
C4 x 1 1/8 x 1/4	8	*		4) Standard Color: Polyester-Gray; Vinyl Ester-Beige			
C3 x 1 x 3/16	8	*		5) Contact Enduro for shapes, resin system, or colors not listed.			
C2 x 1 x 3/16	Note 1	*					

FRP Shapes: Properties

Mechanical	Longitudinal	FR - P	FR - V	Transverse	FR - P	FR - V
Tensile Strength, PSI (ASTM D638)		30,000	35,000		7,000	10,000
Compressive Strength, PSI (ASTM D695)		30,000	35,000		15,000	20,000
Flexural Strength, PSI (ASTM D790)		30,000	35,000		10,000	14,000
Tensile Modulus, PSI x 10 ⁶ (ASTM D638)		2.5	3.0		0.8	1.0
Compressive Modulus, PSI x 10 ⁶ (ASTM D695)		2.5	2.5		1.0	1.2
Flexural Modulus, PSI x 10 ⁶ (ASTM D790)		1.6	2.0		0.8	1.0
Shear Strength, PSI		5,500	7,000		5,500	6,000
Bearing Stress, PSI		30,000	35,000		30,000	35,000
Barcol Hardness (ASTM D2583)		50	50		50	50
Izod Impact Strength, Ft.-Lbs./notch in. (ASTM D256)		25	30		4	5
Modulus of Elasticity, PSI x 10 ⁶		2.5	3.0		Full Section in Bending	
Tensile Strength, PSI		20,000	25,000		Full Section in Bending	
Compressive Strength, PSI		20,000	25,000		Full Section in Bending	
Thermal				Electrical		
Coefficient of Expansion, In./In.°F (ASTM D696)	5 x 10 ⁻⁶			Strength, short term in oil, 1/8", vpm (ASTM D149)		200
Conductivity, BTU per SF/Hr.°F/In. (ASTM C1776)	4			Electric Strength, short term in oil, KV/In.		35
Specific Heat, BTU/Lb.°F	0.28			Dielectric Constant, 60 Hz. (ASTM D150)		5.6, 5.2
				Dissipation Factor, 60 Hz. (ASTM D150)		0.03
				Arc Resistance, seconds (ASTM D495)		120
Fire Retardant				Other		
Flame Spread Rating (ASTM E84)	15			Density, Lbs./In. ³ (ASTM D792)		0.065
Flame Resistance, ign/burn seconds (FTMS 406-2023)	75/75			Specific Gravity (ASTM D792)		1.8
Intermittent Flame Rating (HLT-15 Test)	100			Water Absorption, % (ASTM D570)		0.5
Flammability (ASTM D635): Burn Time = 5 seconds; Extent = 15mm						

Tuff Span FRP Structural

8F6 Purlin/Girt

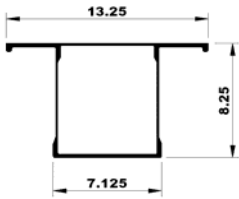

- W = 6.1 lb/ft
- A = 8 in²
- I_{xx} = 93 in⁴
- I_{yy} = 98 in⁴
- E = 3,841,000 psi
- G = 450,000 psi
- M = 456,000 lb-in

Span (Ft.)	Allowable Uniform Load - Unbraced													
	L/D = 120			w/Stiffeners		Wind/Wall		L/D = 180			w/Stiffeners		Wind/Wall	
	1	2	3	2	3	2	3	1	2	3	2	3	2	3
16	388	180	205	290	330	632	731	258	180	205	290	330	622	488
17	323	169	193	273	310	560	610	215	169	193	273	310	519	407
18	272	160	182	258	293	499	514	181	160	182	258	293	437	342
19	231	152	172	244	278	448	437	154	152	172	244	278	372	291
20	198	144	164	232	264	404	374	132	144	164	232	250	319	250
21	171	137	156	221	251	367	324	114	137	156	221	216	275	216
22	149	131	149	211	240	334	281	99	131	149	211	188	239	188
23	130	125	142	202	229	306	246	87	125	142	202	164	210	164
24	115	120	136	193	217	277	217	77	120	136	184	144	184	144
25	102	115	131	186	192	245	192	68	115	128	163	128	163	128
26	90	111	126	178	170	218	170	60	111	114	145	114	145	114
27	81	107	121	167	152	194	152	54	107	101	130	101	130	101
28	72	103	117	155	136	174	136	48	103	91	116	91	116	91
29	65	99	113	145	123	157	123	43	99	82	105	82	105	82
30	59	96	109	135	111	142	111	39	94	74	94	74	94	74
	FOS = 2.5					FOS = 1.88		FOS = 2.5			FOS = 1.88			

Single span load capacity is the same for 8F6 Beams with or without web stiffeners and for wind or bearing load.

12F12 Flanged Tube

- W = 12 lb/ft
- A = 12.64 in²
- I_{xx} = 284.26 in⁴
- I_{yy} = 118.31 in⁴
- E = 4,180,000 psi
- G = 425,000 psi
- M = 1,225,000 lb-in
- r = 3.0572 in
- Bf/Bt = 32
- K = 1

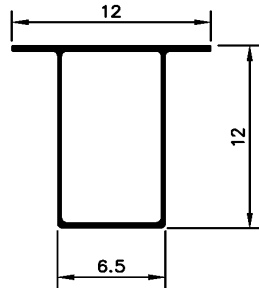

Span (Ft.)	Allowable Uniform Load - Unbraced					
	L/D = 120		L/D = 180		L/D = 240	
	1	2	1	2	1	2
21	570	741	380	741	285	687
22	496	675	331	675	248	597
23	434	618	289	618	217	523
24	382	567	255	567	191	460
25	338	523	225	523	169	407
26	300	483	200	483	150	362
27	268	448	179	431	134	323
28	241	417	160	386	120	290
29	217	388	144	348	108	261
30	196	363	130	314	98	236
31	177	340	118	285	89	214
32	161	319	107	259	81	194
33	147	300	98	236	73	177
34	134	283	90	216	67	162
35	123	267	82	198	62	148

Beam FOS = 2.5

Lth (Ft.)	Column Load	
	Lth (Ft.)	Axial (Lbs.)
6	6	55349
7	7	50850
8	8	47249
9	9	44285
10	10	41792
11	11	39658
12	12	37804
13	13	36176
14	14	34731
15	15	33438
16	16	32272
17	17	31214
18	18	30248
19	19	29361
20	20	28545

Col. FOS = 3

18F17 Flanged Tube

- W = 16.75 lb/ft
- A = 22.47 in²
- I_{xx} = 1197.3 in⁴
- I_{yy} = 279.7 in⁴
- E = 3,967,000 psi
- G = 425,000 psi
- M = 2,000,000 lb-in
- r = 3.53 in
- Bf/Bt = 20.8
- K = 1

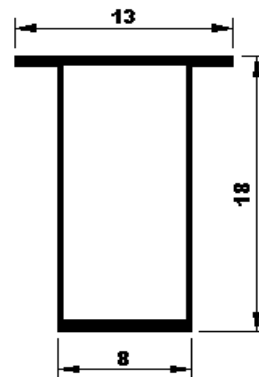

Span (Ft.)	Allowable Uniform Load - Unbraced					
	L/D = 120		L/D = 180		L/D = 240	
	1	2	1	2	1	2
31	555	555	472	555	354	555
32	521	521	429	521	322	521
33	490	490	392	490	294	490
34	461	461	358	461	269	461
35	435	435	328	435	246	435
36	412	412	302	412	226	412
37	390	390	278	390	208	390
38	369	369	256	369	192	369
39	351	351	237	351	178	351
40	330	333	220	333	165	333
41	306	317	204	317	153	317
42	285	302	190	302	142	302
43	266	288	177	288	133	288
44	248	275	165	275	124	275
45	232	263	154	263	116	263

Beam FOS = 2.5

Lth (Ft.)	Column Load	
	Lth (Ft.)	Axial (Lbs.)
11	11	72396
12	12	69013
13	13	66041
14	14	63403
15	15	61042
16	16	58914
17	17	56982
18	18	55218
19	19	53600
20	20	52109
21	21	50730
22	22	49448
23	23	48254
24	24	47137
25	25	46091

Col. FOS = 3

Tuff Span FRP Structural

6 x 6 x 3/8 Wide Flange

W = 5.3 lb/ft
 A = 6.48 in²
 I_{xx} = 40.129 in⁴
 I_{yy} = 13.52 in⁴
 E = 2,600,000 psi
 G = 425,000 psi
 F_b = 8,125 psi
 r = 1.45 in
 A_w = 1.97 in²
 S_{xx} = 13.37
 B_f/B_t = 16
 K = 1

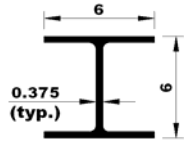

Allowable Uniform Load - Braced							
Span (Ft.)	Stress F _b _F _v	L/D = 120		L/D = 180		L/D = 240	
		1	2	1	2	1	2
4	1478	2955	3878	1970	2585	1477	1939
5	1182	1923	2758	1282	1838	962	1379
6	985	1305	2024	870	1349	653	1012
7	844	918	1520	612	1013	459	760
8	739	665	1164	443	776	333	582
9	657	495	906	330	604	247	453
10	591	377	716	251	478	188	358
11	537	293	574	195	383	146	287
12	493	231	466	154	310	116	233
13	429	186	382	124	255	93	191
14	369	151	317	101	211	76	158
15	322	125	265	83	177	62	133
16	283	104	224	69	149	52	112

Bending FOS = 2.5

Shear FOS = 3.0

Column Load	
Lth (Ft.)	Axial (Lbs.)
1	43875
2	43875
3	43875
4	43875
5	43875
6	36015
7	27712
8	22085
9	18077
10	15113
11	12852
12	11085
13	9675

Col. FOS = 3

12S12 Flanged Tube

W = 12 lb/ft
 A = 12.6429 in²
 I_{xx} = 231.2 in⁴
 I_{yy} = 140.9 in⁴
 E = 4,180,000 psi
 G = 425,000 psi
 M = 908,000 lb-in
 r = 4.53 in
 B_f/B_t = 17.33
 K = 1

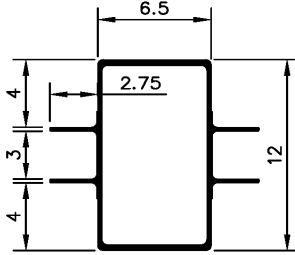

Allowable Uniform Load - Unbraced						
Span (Ft.)	L/D = 120		L/D = 180		L/D = 240	
	1	2	1	2	1	2
6	6726	6726	6726	6726	6726	6726
7	4941	4941	4941	4941	4941	4941
8	3783	3783	3783	3783	3783	3783
9	2989	2989	2989	2989	2946	2989
10	2421	2421	2421	2421	2148	2421
11	2001	2001	2001	2001	1614	2001
12	1681	1681	1657	1681	1243	1681
13	1433	1433	1303	1433	978	1433
14	1235	1235	1044	1235	783	1235
15	1076	1076	848	1076	636	1076
16	946	946	699	946	524	946
17	838	838	583	838	437	838
18	736	747	491	747	368	747
19	626	671	417	671	313	671
20	537	605	358	605	268	605

Beam FOS = 2.5

Col. FOS = 3

14B10 Rectangular Tube

W = 10 lb/ft
 A = 12.96 in²
 I_{xx} = 354.8 in⁴
 I_{yy} = 57.5 in⁴
 E = 4,340,000 psi
 G = 425,000 psi
 M = 1,350,000 lb-in
 r = 2.09 in
 B_f/B_t = 10.25
 K = 1

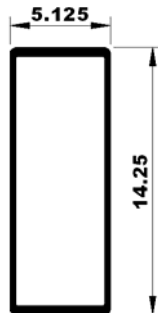

Allowable Uniform Load - Unbraced						
Span (Ft.)	L/D = 120		L/D = 180		L/D = 240	
	1	2	1	2	1	2
21	739	816	493	816	369	816
22	643	744	428	744	321	744
23	562	681	375	681	281	677
24	495	625	330	625	248	596
25	438	576	292	576	219	528
26	389	533	260	533	195	469
27	348	494	232	494	174	419
28	312	459	208	459	156	375
29	281	428	187	428	140	338
30	253	400	169	400	127	305
31	230	375	153	369	115	277
32	209	352	139	335	104	252
33	190	331	127	306	95	229
34	174	311	116	280	87	210
35	160	294	106	256	80	192

Beam FOS = 2.5

Col. FOS = 3

Tuff Span FRP Structural

4 x 4 x 1/4 Square Tube

W = 3.25 lb/ft
 A = 3.74 in²
 I_{xx} = 8.82 in⁴
 I_{yy} = 8.82 in⁴
 E = 2,600,000 psi
 G = 425,000 psi
 F_b = 6,158 psi
 r = 1.53 in
 A_w = 1.75 in²
 S_{xx} = 4.41 in³
 B_f/B_t = 16
 K = 1

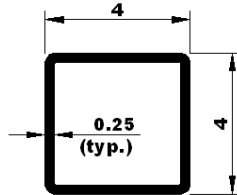

Span (Ft.)	Stress F _b _F _v	Allowable Uniform Load						Column Load	
		L/D= 120		L/D= 180		L/D= 240		Lth (Ft.)	Axial (Lbs.)
		1	2	1	2	1	2		
6	503	407	503	272	503	204	411	6	19191
7	369	266	369	178	369	133	279	7	19191
8	283	183	283	122	263	91	197	8	19191
9	223	131	223	87	192	65	144	9	16646
10	181	97	181	64	144	48	108	10	14515
11	150	73	150	49	110	37	83	11	12824
12	126	57	126	38	86	28	65	12	11452
13	107	45	103	30	69	22	52	13	10321
14	92	36	84	24	56	18	42	14	9373

Shear FOS = 3

Bending FOS = 2.5

Col. FOS = 3

3 x 3 x 1/4 Square Tube

W = 2.2 lb/ft
 A = 2.74 in²
 I_{xx} = 3.5 in⁴
 I_{yy} = 3.5 in⁴
 E = 2,600,000 psi
 G = 425,000 psi
 F_b = 7,863 psi
 r = 1.13 in
 A_w = 1.25 in²
 S_{xx} = 2.33 in³
 B_f/B_t = 12
 K = 1

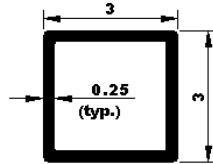

Span (Ft.)	Stress F _b _F _v	Allowable Uniform Load						Column Load	
		L/D= 120		L/D= 180		L/D= 240		Lth (Ft.)	Axial (Lbs.)
		1	2	1	2	1	2		
1	3750	3750	3750	3750	3750	3750	3750	1	17955
2	1875	1875	1875	1875	1875	1406	1875	2	17955
3	1250	1107	1250	738	1250	553	973	3	17955
4	763	527	763	352	686	264	514	4	17955
5	489	287	489	192	398	144	298	5	17658
6	339	172	339	115	248	86	186	6	13932
7	249	111	246	74	164	55	123	7	11402
8	191	75	170	50	113	38	85	8	9585
9	151	53	122	36	81	27	61	9	8224

Shear FOS = 3

Bending FOS = 2.5

Col. FOS = 3

2 x 2 x 1/4 Square Tube

W = 1.4 lb/ft
 A = 1.74 in²
 I_{xx} = 0.91 in⁴
 I_{yy} = 0.91 in⁴
 E = 2,600,000 psi
 G = 425,000 psi
 F_b = 11,099 psi
 r = 0.73 in
 A_w = 0.75 in²
 S_{xx} = 0.91 in³
 B_f/B_t = 8
 K = 1

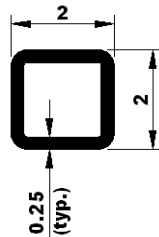

Span (Ft.)	Stress F _b _F _v	Allowable Uniform Load						Column Load	
		L/D= 120		L/D= 180		L/D= 240		Lth (Ft.)	Axial (Lbs.)
		1	2	1	2	1	2		
1	2250	2250	2250	2250	2250	2205	2250	1	16094
2	1125	977	1125	652	1125	489	863	2	16094
3	748	338	685	225	457	169	342	3	12344
4	421	151	328	101	218	76	164	4	8493
5	269	80	179	53	119	40	89	5	6354
6	187	47	107	31	72	23	54	6	5013
7	137	30	69	20	46	15	35	7	4103
8	105	20	47	13	31	10	24	8	3449
9	83	14	33	9	22	7	17	9	2959

Shear FOS = 3

Bending FOS = 2.5

Col. FOS = 3

1 5/8 x 1 5/8 x 1/8 Square Tube

W = 0.56 lb/ft
 A = 0.74 in²
 I_{xx} = 0.28 in⁴
 I_{yy} = 0.28 in⁴
 E = 2,600,000 psi
 G = 425,000 psi
 F_b = 7,346 psi
 r = 0.61 in
 A_w = 0.34 in²
 S_{xx} = 0.339 in³
 B_f/B_t = 13
 K = 1

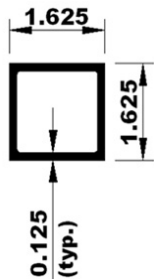

Span (Ft.)	Stress F _b _F _v	Allowable Uniform Load						Column Load	
		L/D= 120		L/D= 180		L/D= 240		Lth (Ft.)	Axial (Lbs.)
		1	2	1	2	1	2		
1	1020	1020	1020	1020	1020	834	1020	1	4530
2	415	328	415	219	415	164	311	2	4530
3	184	109	184	72	154	54	115	3	4157
4	104	48	104	32	71	24	53	4	2860
5	66	25	57	17	38	12	29	5	2140
6	46	15	34	10	23	7	17	6	1688
7	34	9	22	6	14	5	11	7	1382
8	26	6	15	4	10	3	7	8	1161
9	20	4	10	3	7	2	5	9	997

Shear FOS = 3

Bending FOS = 2.5

Col. FOS = 3

Tuff Span FRP Structural

C10 x 2 3/4 x 3/8 Channel

W = 4.27 lb/ft
I_{xx} = 69.09 in⁴
E = 2,600,000 psi
G = 425,000 psi
F_b = 5,805 psi
A_w = 3.47 in²
S_{xx} = 13.82 in³
B_f/B_t = 7.33

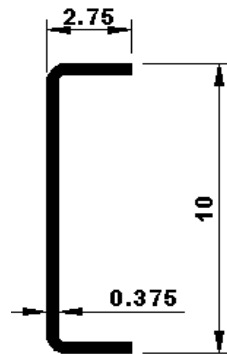

Allowable Uniform Load - Braced							
Span (Ft.)	Stress F _b _F _v	L/D= 120		L/D= 180		L/D= 240	
		1	2	1	2	1	2
12	371	371	371	266	371	200	371
13	316	316	316	214	316	160	316
14	273	261	273	174	273	131	273
15	238	215	238	143	238	108	229
16	209	179	209	120	209	90	194
17	185	151	185	101	185	75	165
18	165	128	165	85	165	64	141
19	148	110	148	73	148	55	122
20	134	95	134	63	134	47	106

Shear FOS = 3

Bending FOS = 2.5

C8 x 1 3/4 x 5/16 Channel

W = 2.5 lb/ft
I_{xx} = 25.38 in⁴
E = 2,600,000 psi
G = 425,000 psi
F_b = 7,484 psi
A_w = 2.3 in²
S_{xx} = 6.35 in³
B_f/B_t = 5.61

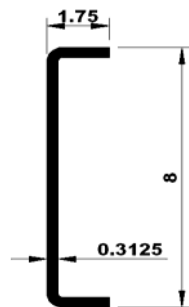

Allowable Uniform Load - Braced							
Span (Ft.)	Stress F _b _F _v	L/D= 120		L/D= 180		L/D= 240	
		1	2	1	2	1	2
8	495	479	495	319	495	240	468
9	391	349	391	232	391	174	353
10	317	261	317	174	317	130	271
11	262	200	262	133	262	100	212
12	220	156	220	104	220	78	169
13	187	124	187	83	182	62	136
14	162	101	162	67	149	50	112
15	141	82	141	55	123	41	92
16	124	68	124	46	103	34	77

Shear FOS = 3

Bending FOS = 2.5

C6 x 1 5/8 x 5/16 Channel

W = 2.1 lb/ft
I_{xx} = 11.2 in⁴
E = 2,600,000 psi
G = 425,000 psi
F_b = 8,029 psi
A_w = 1.68 in²
S_{xx} = 3.73 in³
B_f/B_t = 5.21

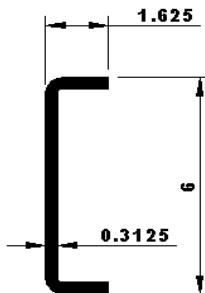

Allowable Uniform Load - Braced							
Span (Ft.)	Stress F _b _F _v	L/D= 120		L/D= 180		L/D= 240	
		1	2	1	2	1	2
6	555	495	555	330	555	248	478
7	407	327	407	218	407	164	331
8	312	226	312	151	312	113	237
9	246	163	246	108	233	81	174
10	200	120	200	80	176	60	132
11	165	92	165	61	136	46	102
12	139	71	139	47	107	36	80
13	118	56	118	38	85	28	64
14	102	45	102	30	69	23	52

Shear FOS = 3

Bending FOS = 2.5

C6 x 1 5/8 x 1/4 Channel

W = 1.7 lb/ft
I_{xx} = 10.35 in⁴
E = 2,600,000 psi
G = 425,000 psi
F_b = 6,507 psi
A_w = 1.38 in²
S_{xx} = 3.45 in³
B_f/B_t = 6.5

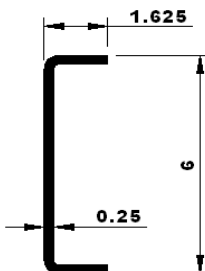

Allowable Uniform Load - Braced							
Span (Ft.)	Stress F _b _F _v	L/D= 120		L/D= 180		L/D= 240	
		1	2	1	2	1	2
4	935	935	935	812	935	609	935
5	599	599	599	476	599	357	599
6	416	416	416	299	416	224	416
7	305	297	305	198	305	149	296
8	234	206	234	138	234	103	213
9	185	149	185	99	185	74	158
10	150	110	150	74	150	55	120
11	124	84	124	56	123	42	93
12	104	65	104	44	97	33	73

Shear FOS = 3

Bending FOS = 2.5

Tuff Span FRP Structural

C4 x 1 1/8 x 1/4 Channel

W = 1.13 lb/ft
I_{xx} = 2.66 in⁴
E = 2,600,000 psi
G = 425,000 psi
F_b = 9,228 psi
A_w = 0.88 in²
S_{xx} = 1.32 in³
B_f/B_t = 4.5

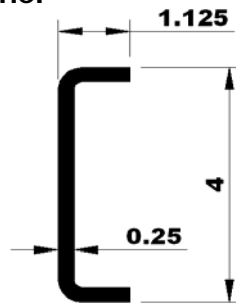

Allowable Uniform Load - Braced							
Span (Ft.)	Stress F _b _F _v	L/D= 120		L/D= 180		L/D= 240	
		1	2	1	2	1	2
3	880	824	880	549	880	412	713
4	508	396	508	264	508	198	381
5	325	216	325	144	297	108	222
6	226	130	226	87	186	65	139
7	166	84	166	56	123	42	92
8	127	57	127	38	85	29	64
9	100	41	92	27	61	20	46

Shear FOS = 3 Bending FOS = 2.5

C3 x 1 x 3/16 Channel

W = 0.68 lb/ft
I_{xx} = 0.948 in⁴
E = 2,600,000 psi
G = 425,000 psi
F_b = 7,857 psi
A_w = 0.49 in²
S_{xx} = 0.632 in³
B_f/B_t = 5.33

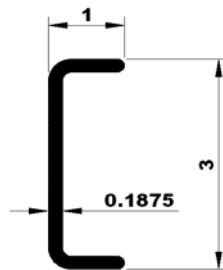

Allowable Uniform Load - Braced							
Span (Ft.)	Stress F _b _F _v	L/D= 120		L/D= 180		L/D= 240	
		1	2	1	2	1	2
1	1470	1470	1470	1470	1470	1470	1470
2	735	735	735	589	735	442	708
3	368	326	368	217	368	163	307
4	207	151	207	100	206	75	155
5	132	81	132	54	116	40	87
6	92	48	92	32	71	24	53
7	68	31	68	20	46	15	35

Shear FOS = 3 Bending FOS = 2.5

6 x 6 x 3/8 Angle

W = 2.2 lb/ft
A = 2.74 in²
I_{min} = 3.5 in⁴
E = 2,600,000 psi
r = 1.13 in
B_f/B_t = 12
K = 1

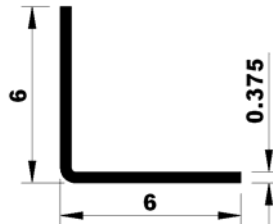

Column Load	
Length (Ft.)	Axial (Lbs.)
3	17955
4	17955
5	17658
6	13932
7	11402
8	9585
9	8224
10	7172

Column FOS = 3

4 x 4 x 3/8 Angle

W = 2.22 lb/ft
A = 2.81 in²
E = 2,600,000 psi
r = 0.77 in
B_f/B_t = 10.67
K = 1

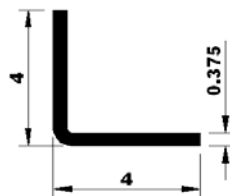

Column Load	
Length (Ft.)	Axial (Lbs.)
3	5248
4	4480
5	3962
6	3584
7	3293
8	3060
9	2868
10	2706

Column FOS = 3

3 x 3 x 3/8 Angle

W = 1.63 lb/ft
A = 2.06 in²
E = 2,600,000 psi
r = 0.57 in
B_f/B_t = 12
K = 1

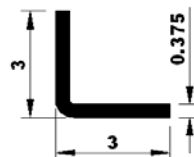

Column Load	
Length (Ft.)	Axial (Lbs.)
3	3261
4	2783
5	2462
6	2227
7	2046
8	1901
9	1782
10	1682

Column FOS = 3